

TITANMATE™

TMAR2-40 Tool Support Arm

The TITANMATE™ TMAR2-40 is a rugged articulating tool support arm ergonomically designed to provide fingertip control for the most demanding applications. The sturdy tubular steel swing arm is connected to the base by means of a 1" (25.4mm) hardened and ground shaft. Both the main shaft and the center shaft utilize high quality roller bearings to minimize friction while maximizing precision and reliability. The twin parallel arms are made of heavy gage aluminum tubing which effectively neutralizes vibration and torque reaction. The hybrid lift system combines the best attributes of a sealed high pressure gas spring with the flexibility of an adjustable pneumatic cylinder.

The standard TMAR2-40 is capable of balancing a 10 Lb. (4.5 Kg.) power tool and absorbing 35 Ft. Lb. (47.5 Nm.) of torque reaction, yet is so sensitive that it can be used with the most delicate taps and bits.

The TMAR2-40 can be mounted on a work bench or portable cart or can be inverted for overhead mounting and is the perfect complement to any machining center or work station.

Standard features include:

- Multi position tool holder
- Adjustable air/gas lift assist package
- Hardened and ground steel shafts
- Precision bearings
- Base mount with leveling screws
- Welded steel swing arm

Optional features include:

- Custom motor mounts
- Power tools
- Quick release chucks and collets
- Tap holders
- Keyless chucks
- Stud drivers
- Work carts
- Floor pedestals
- Rigid tool holders

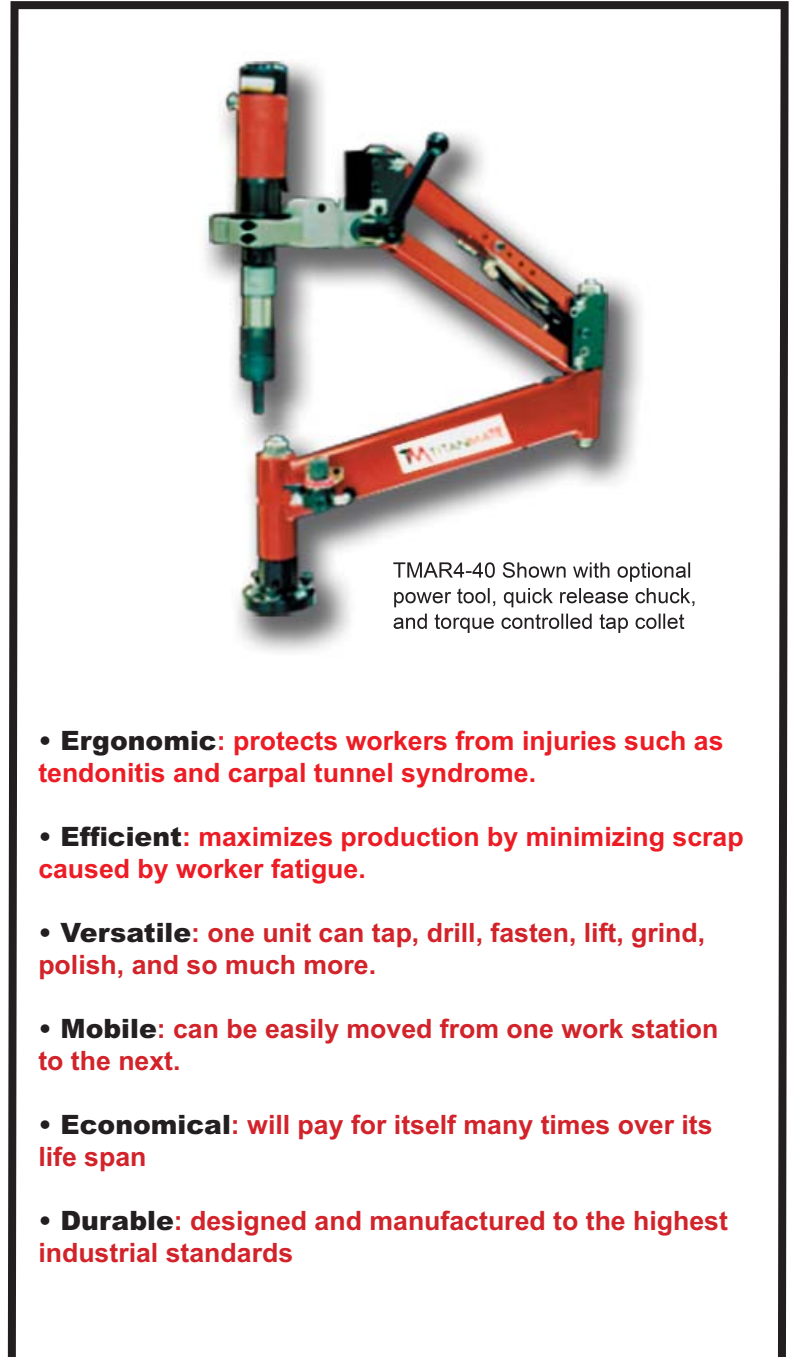

TMAR2-40 Shown with optional power tool, quick release chuck, and torque controlled tap collet

- **Ergonomic:** protects workers from injuries such as tendonitis and carpal tunnel syndrome.
- **Efficient:** maximizes production by minimizing scrap caused by worker fatigue.
- **Versatile:** one unit can tap, drill, fasten, lift, grind, polish, and so much more.
- **Mobile:** can be easily moved from one work station to the next.
- **Economical:** will pay for itself many times over its life span
- **Durable:** designed and manufactured to the highest industrial standards

TMAR240_032806EJW01

TITAN® Quality Assembly Tools Since 1920

Titan Tool Company, Inc.

7410 West Ridge Road • Fairview, PA 16415 • (814)474-1583 • FAX (814)474-5337
on the web at www.titantoolco.com • E-mail: titan@titantoolco.com



TMAR2-40 Tool Support Arm

Specifications and Details

Reach

The **TMAR2-40** can reach 40" (1016mm) in all directions. For applications requiring more reach, special length arms can be provided; generally this is done in 6" (152mm) increments. Please contact Titan Tool Company or your local representative for price and availability.

Work Envelope

The maximum work envelope of the **TMAR2-40** starts 14" (356mm) from the main shaft and extends to 40" (1016mm) in all directions giving you a work envelope of 33.7 square feet (2.8 square meters).

Vertical Clearance

Maximum vertical clearance on the **TMAR2-40** is 23.75" (603mm); Minimum vertical clearance is 7.5" (191mm). This is the measurement from the bottom of the base mount to the bottom face of the tool holder in both the full up and full down positions. Work height can be changed a few inches at a time by moving the gas spring and air cylinder to one of the alternate mounting holes found on the upper parallel arm.

Payload

The high pressure gas spring is designed to hold the empty weight of the parallel arms and tool holder. Once the payload (power tool) is installed, simply adjust the air regulator to achieve the desired arm strength. Arm strength is a subjective matter best determined by each individual operator; some may prefer to have the arm retract fully to its vertical limit while others may prefer to have the arm retract more gently, allowing the power tool to float just slightly above the work piece.

Mounting and Leveling

All **TITANMATE™** Tool Support Arms are equipped with a heavy duty steel base which is bolted to the work surface and leveled with a series of three leveling screws which stabilize the arm and minimize drift. Further stabilization can be achieved by adjusting the brass tipped friction screws that are located on each shaft.

Mounting Position

The **TMAR2-40** is designed to be mounted on a flat horizontal surface such as a work bench, or can be inverted and suspended from an overhead support to free up valuable work space.

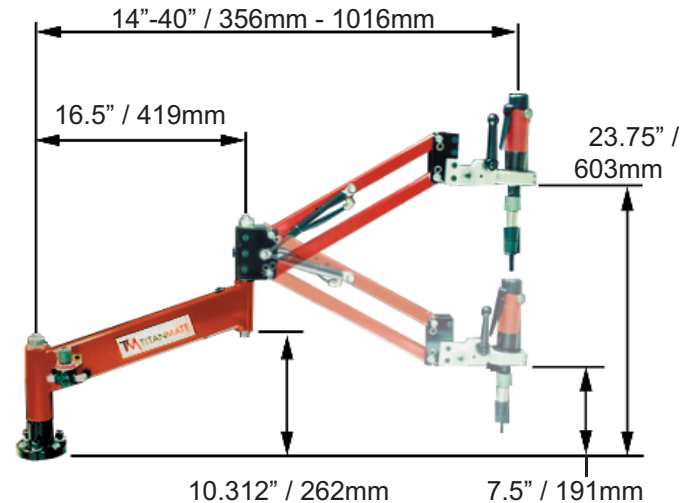

Standard Specifications

Payload	10lbs / 4.5 Kg. Max
Power Tool Dia.	2" / 58mm Max
Torque	35ft.lbs / 47.5 NM Max
Working Dia	6'-8" / 2 M Max
Unit Weight	23 lbs / 10.5 Kg.

Multi Position Tool Holder



The multi position Tool Holder is standard on all **TITANMATE™** Tool Support Arms. The clamping mechanism is machined to fit your power tool, which gives you a full 360 degrees of tool support to prevent slippage or damage. The pivot block and clamp can be independently adjusted to any angle. Once in position these components are securely locked into position by a set of spring loaded handles. Once locked, the handles can be moved out of the way for additional clearance.